

Single-chamber Bat House (wall mounted)

Materials (makes one house)

¼ sheet (2' x 4') ½" AC, BC or T1-11 (outdoor grade) plywood
 One piece 1" x 2" (¾" x 1½" finished) x 8' pine (furring strip)
 20 to 30 exterior-grade screws, 1"
 One pint dark, water-based stain, exterior grade
 One pint water-based primer, exterior grade
 One quart flat, water-based paint or stain, exterior grade
 One tube paintable latex caulk
 1" x 4" x 28" board for roof (optional, but highly recommended)
 Black asphalt shingles or galvanized metal (optional)
 6 to 10 roofing nails, ¾" (if using shingles or metal roofing)

Recommended tools

Table saw or handsaw	Caulking gun
Variable-speed reversing drill	Paintbrushes
Screwdriver bit for drill	Hammer (optional)
Tape measure or yardstick	Tin snips (optional)

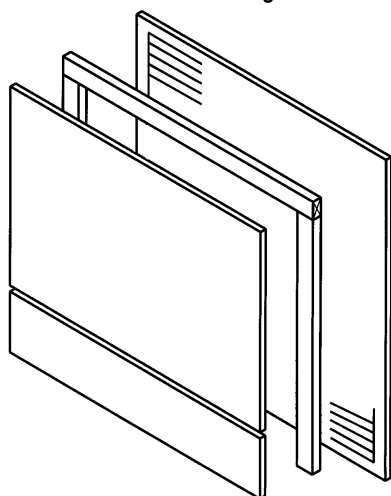
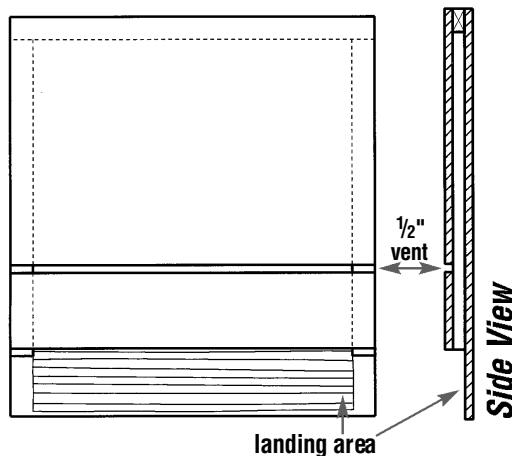

More bat-house plans and additional information can be found in BCI's *Bat House Builder's Handbook*, available at www.batcatalog.com.

Construction

- Measure and cut plywood into three pieces:
 26½" x 24" 16½" x 24" 5" x 24"
- Roughen inside of backboard and landing area by cutting horizontal grooves with sharp object or saw. Space grooves ¼" to ½" apart, cutting ½" to ⅙" deep.
- Apply two coats of dark, water-based stain to interior surfaces. Do not use paint, as it will fill grooves.
- Cut furring strip into one 24" and two 20½" pieces.
- Attach furring strips to back, caulking first. Start with 24" piece at top. Roost chamber spacing is ⅜".
- Attach front to furring strips, top piece first (caulk first). Leave ½" vent space between top and bottom front pieces.
- Caulk all outside joints to further seal roost chamber.
- Attach a 1" x 4" x 28" board to the top as a roof (optional, but highly recommended).
- Apply three coats of paint or stain to the exterior (use primer for first coat).
- Cover roof with shingles or galvanized metal (optional).
- Mount on building (south or east sides usually best).

Optional modifications to the single-chamber bat house

- Wider bat houses can be built for larger colonies. Be sure to adjust dimensions for back and front pieces and ceiling strip. A ¾" support spacer may be needed in the center of the roosting chamber for bat houses over 24" wide to prevent warping.
- To make a taller version for additional temperature diversity, use these modifications: From a 2' x 8' piece of plywood, cut three pieces: 51" x 24", 33" x 24" and 12" x 24". Cut two 8' furring strips into one 24" and two 44" pieces. Follow assembly procedure above.
- Two bat houses can be placed back-to-back, mounted between two poles, to create a three-chamber nursery house. Before assembly, cut a horizontal ⅜" slot in the back of each house about 9" from the bottom edge of the back piece to permit movement of bats between houses. Two pieces of wood, 1" x 4" x ¾", screwed horizontally to each side, will join the two boxes. Leave a ⅜" space between the two houses, and roughen the wood surfaces or cover the back of each with plastic mesh (see item 5 below). Do not cover the rear exit slots with mesh. One 1" x 4" x 34" vertical piece, attached to each side over the horizontal pieces, blocks light but allows bats and air to enter. A galvanized metal roof, covering both houses, protects the center roosting area from rain. Eaves should be about 3" in southern areas and about 1½" in the north.
- Ventilation may not be necessary in cold climates. In this case, the front should be a single piece 23" long. Smaller bat houses like this one will be less successful in cool climates. However, those mounted on buildings maintain thermal stability better and are more likely to attract bats.
- Durable plastic mesh can be substituted to provide footholds for bats. Attach one 20" x 24½" piece to backboard after staining interior, but prior to assembly.